

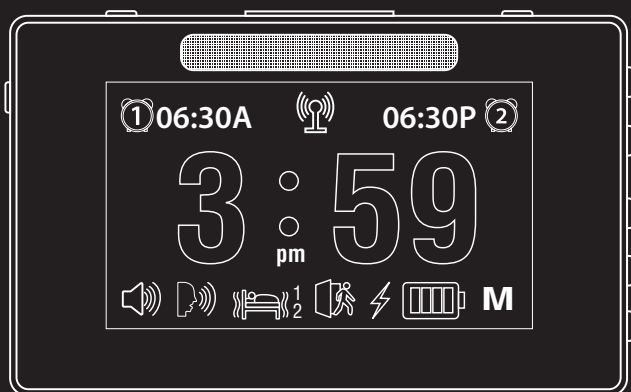

SEREONIC[®]ALERT

USER'S MANUAL VISUAL ALERT SYSTEM



MODEL CA-360Q

WARNING: Do NOT install regular batteries in the unit, use only NiMH rechargeable batteries.

TABLE OF CONTENTS

CA-360Q Features	03
Important Safety Instructions	04
General Description	05
Package Contents	06
Unit Overview	07
Display Details	08
Installation	10
Setup Instructions	12
Enabling alerts to unregistered CA-AX	15
Motion detection alert	15
Connecting an external lamp	15
Energy Saving Mode	15
CA-AX Special Warning Message	16
Adding Extra Wireless Sensor Accessories	17
View registered accessories	17
Clear All Accessories	17
System Menu	18
System Reset	20
Technical Specifications	21
FAQ	22
Warranty Service Information	24
FCC & IC Information	25

Features:

- ⊙ 2.4GHz Wireless Smart-Code Technology
 - 360 full coverage of your entire home
- ⊙ Advanced Visual alert system alerts you to daily sounds:
 - Alarm clock
 - Phone / cell
 - Baby's crying
 - Weather alerts (external alarm)
 - Doorbell
 - Audio alarms
 - Motion Sensor
 - SOS paging and more
- ⊙ Multiple alerting outputs
 - Loudspeaker
 - Visual icons
 - Bright flasher
 - Alerting accessory
 - Bed shakers
- ⊙ Dual alarm settings (12/24-hr format)
- ⊙ Auto clock-dimming for a softer display at night
- ⊙ Dual bed shaker output jacks
- ⊙ Wireless Smart-Code technology supports thousands of systems.
- ⊙ Internal antenna design for long range operations
- ⊙ Analog phone jacks for landline telephone ringing
- ⊙ Output jack to control a 100-watt max. lamp module (optional)
- ⊙ Use 520 Hz square-wave technology for maximum audio alert output
- ⊙ Built-in bright flashlight (with brightness control)
- ⊙ 2-way SOS (help) paging
- ⊙ Simple installation – just plug and use.
- ⊙ Battery back-up (4x AA NiMH)
- ⊙ AC adapter 110/240 VAC, 50/60 Hz operation
- ⊙ 7 days full function battery back-up
- ⊙ Contemporary design with large 5" color display
- ⊙ User select color for icons and clocks.
- ⊙ Intuitive alerting icons
- ⊙ User select show/hide main clock.
- ⊙ Multiple language alert announces.
- ⊙ Ignore accessories (in master mode Only)
- ⊙ Main power lost warning
- ⊙ Option to detect unregistered CA-AX audio sensors.
- ⊙ Lost contact / Low battery warning on registered CA-AX sensors

Important Safety Instructions:

When using the **SEREONIC Alert** Model CA-360Q, to reduce the risk of fire, electrical shock or injury to persons, basic safety precautions should always be followed, including the following:

01. Read all instructions before using.
02. Use NiMH rechargeable batteries only, use of non-rechargeable batteries will damage the unit and void warranty.
03. Do not mount or place Master-Unit on a small surface. Metal surfaces can reduce wireless signal transmission.
04. Always disconnect phone cord from wall jack before changing /installing batteries.
05. To reduce injury risk, close supervision is necessary when appliance is used near children.
06. Do not contact moving parts or exposed metal surfaces.
07. Only use attachments recommended / sold by the manufacturer.
08. Do not use outdoors. Do not use near water.
09. To disconnect device, remove attached plugs from the device.
10. Do not unplug the unit by pulling the cord – grasp plug, not cord.
11. Unplug unit from outlet when not in use / before servicing or cleaning.
12. Do not operate an appliance with a damaged cord or plug; do not operate any appliance after it malfunctions, is dropped or damaged in any manner. Return appliance to nearest authorized facility for examination; repair or electrical / mechanical adjustment.
13. Avoid using telephone products during electrical storms. There is an electrical shock risk from lightning.
14. Do not use telephone to report a gas leak while in the vicinity of the leak.
15. Specifications of this product are subject to change without notice.

General Description:

Model CA-360Q is an advanced wireless visual alert system for the public and specially geared for the hard-of-hearing (HOH). It has a dual-alarm clock with a 5-inch (diagonal) color graphics display and uses an exclusive Smart-Code technology and operates in the 2.4 GHz band. This technology offers a fast response and long-range operation. It can support thousands of systems without the need for channel-setting switches.

The system alerts users to multiple different household functions/events using five (5) alerting outputs: speaker, flasher, bed-shaker, large visual icons, and digital voice speech. The display icon shows the name of the alert activation (optional accessories purchased separately).

Different system configurations can be setup on the CA-360Q. The basic system setup can have only one (1) CA-360Q unit as the master, and multiple remote receivers.

Additional wireless sensors, bed-shakers, and remote receivers may be purchased to cover a large home or office. New sensors must be registered to the CA-360Q master-unit before they can be recognized.

(See later "Adding Extra Wireless Sensor Accessories" section).

The CA-360Q, with its new system menu, provide the user options to change some of the visual parameters, such as showing / hiding the main clock, change clock colors, change icons color, change alerting tones, and change voice speech language.

Package Contents:



Base Unit

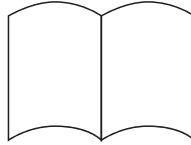

User's Guide

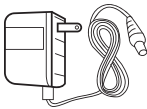

AC Adapter



Phone Cord

Unpack and remove items from the box. Confirm all items are included before disposing of the shipping box.

Items included are:

- 1 – Sereonic Alert CA360Q
- 1 – User's Guide
- 1 – Telephone Cable
- 1 – AC adapter

Note: Batteries are user provided, please make sure you use NiMH Rechargeable Batteries.

Unit Overview:

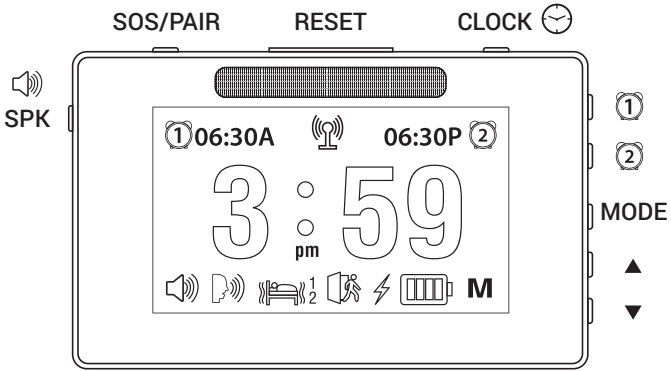

FRONT VIEW

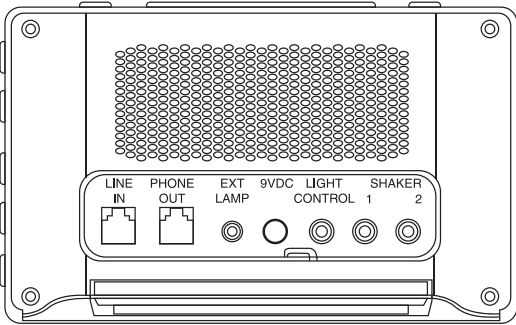

BACK VIEW

Display Details:

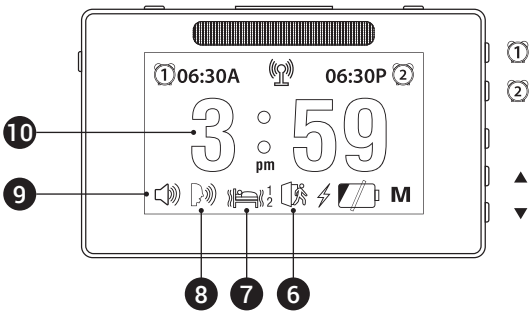
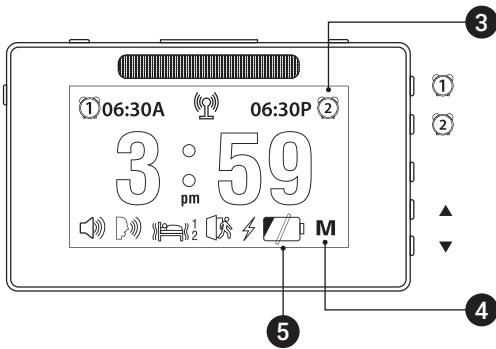
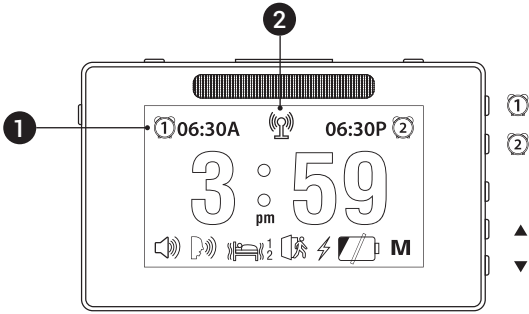

Display Detail Description

- 1** Alarm-1 icon display.
- 2** Detection of unregistered CA-AX audio transmitter icon.
- 3** Alarm-2 icon display.
- 4** System mode icon - (M) Master or (S) Sub.
- 5** Power and battery status icon.
- 6** Motion detection alerts enabled icon.
- 7** Bed shaker connection icon.
- 8** Voice enable icon.
- 9** Speaker volume level – Off – Low – High.
- 10** Main clock.

INSTALLATION

01. Install four AA size rechargeable **NiMH** batteries in battery compartment at bottom of unit. (Batteries not provided)

Warning: Do not use regular batteries, as charging of regular batteries can cause batteries to leak and damage to the unit.

Note: *The CA-360Q will operate without batteries, but installing batteries is highly recommended to continue system operations in case of a power outage.*

02. Plug AC adapter into outlet and connect the plug to the unit.
03. Connect bed shaker to **SHAKER-1** output jack. Bed shakers are sold separately.
04. Press the  button to set the volume (speaker icon).
05. Verify the "M" indicator is shown. Default is master mode.

Land Line Telephone Connection:

01. Connect an analog telephone to the PHONE OUT jack on the back.
02. Connect a telephone cord to the LINE IN jack on the back of the unit.

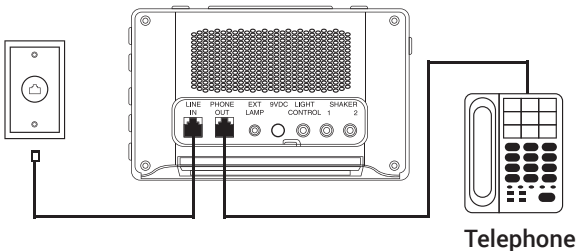



03. Place a call to the telephone number corresponding to the connected telephone line.
04. Verify that all alerting outputs are triggered - display icon, flasher, ring tone, and bed shaker (if connected) – Answer call while the telephone is ringing.
05. Verify that by answering the call (from any telephone), all alerting outputs stop.

INSTALLATION Cont'd:

Pairing Sensor Accessories to the system:

01. A new wireless sensor (example: a wireless doorbell) must be learned (registered) into the CA-360Q unit before it can be recognized.
02. Press and hold the **SOS/PAIR** button for 6 seconds until the unit beeps, display, and announces "**LEARN**". This screen will show the current accessories paired to the system.
03. Press and hold the new accessory's test button for about 6 seconds until the CA-360Q beeps and display the accessory name.
04. While still in the learn mode, repeat step 3 above to learn another accessory. Press the **RESET** button to exit when finished.
05. Test the new wireless accessory by pressing its test button. If the CA-360Q sounds the alarms, the learning was successful. If not, repeat the steps above and learn the accessory again.

Un-Pairing or deleting Sensor Accessories from the system:

01. This function only applies to CA-360Q in master mode.
02. Press and hold the **SOS/PAIR** button for 6 seconds until the unit beeps, display, and announces "**LEARN**". This screen will show the current accessories paired to the system.
03. Use ▲ or ▼ buttons to scroll and select the accessory you want to ignore. Press and hold the  +  buttons for 2 seconds, and the accessory name will be removed from the list.
04. Press the **RESET** button to exit when finished

Note: CA-360Q unit will not be alarmed by the ignored accessory, but other remote receivers will be alerted by the accessory.

SETUP INSTRUCTIONS

Voice Announcement Language Selection

01. Press the **MODE** button for about 3 seconds. The display will show the available language list with the current language selection highlighted.
02. Use the ▲ or ▼ buttons to scroll and press **MODE** again to select. If no voice speech is preferred, select Off from the list. The speech icon with an "X" will be shown for no voice announcements.
03. If there are remote receivers in the system, the remote receiver language will be updated as well.

Quick Self-Test

01. Press **SOS** button once on top of the unit. Verify that alert outputs (speaker, voice, flasher, shaker and alert icon display) lasts for about 45 seconds, then stops.
02. Pressing the **RESET** button will stop the alert.
03. Verify that the flasher can be toggled ON and OFF using the **RESET** button.

Set the Clock

Press the ▲(UP) button for 2 seconds to start.

01. Use the ▲ or ▼ buttons to select 12/24 format, then press **MODE**.
02. Use the ▲ button to change the hour, and the ▼ button to change the minutes. The hours and minutes will continue to scroll when you press the buttons.
03. Press **MODE** or **RESET** button when finished. Clock is set.

Clock Display ON/OFF

01. You can turn OFF the clock display by pressing the ☹ button for 2 seconds or until you hear a beep.
02. When the clock display is off you can Press the ☺ button once to display the date and press it again to display the time momentarily.
03. To enable the clock display again, press the ☺ for 2 seconds or until you hear a beep.

Set the Date:

Press the ▼ (Down) button for 2 seconds to start.

01. Use the ▲ or ▼ buttons to change Year, then press **MODE**.
02. Use the ▲ or ▼ buttons to change Month, then press **MODE**.
03. Use the ▲ or ▼ buttons to select Day, then press **MODE**.
04. Press the 😊 button once will momentarily display the date.

Set Alarm Time:

01. Press ① or ② button until the alarm icon and alarm time start blinking. when the alarm icon and alarm time are blinking, press the ▲ to set hour and ▼ to set minute. The new alarm time will be set when it stops blinking.
02. When the alarm is on, the unit will sound and the connected shaker will shake for 45-seconds, then stops for a 5-minute snooze period. This snooze pattern will repeat for up to one (1) hour. Press and hold the **RESET** button for 2 seconds to stop the snooze function.

Note: **SHAKER-1** and **SHAKER-2** output jack corresponds to Alarm-1 and Alarm-2 individually, but **BOTH** jacks will be active during alerts.









Speaker Volume

Press the 🔊 button to change the speaker volume level off – Low – High. The speaker icon on the bottom left corner indicates the volume level.









Flasher Light Control

Locate the button on the back labeled "**Light Control**". Pressing this button will change the light intensity of the flasher. Press repeatedly to set the desired intensity.









Change Alert Tone

01. Press  +  +  buttons for 2 seconds to access system menu.
02. Use  or  button to scroll to this  icon. Press **MODE** once.
03. Use  or  button to scroll and highlight the desired tone. A short sample of the tone will be played.
04. Press the **MODE** button to confirm.
05. Press **RESET/SNOOZE** to exit system menu.

Change Clock Color

01. Press  +  +  buttons for 2 seconds to access system menu.
02. Use  or  button to scroll to this  icon. Press **MODE** once.
03. Use  or  button to scroll and highlight the desired color.
04. Press the **MODE** button to confirm.
05. Press **RESET/SNOOZE** to exit system menu.

Change Icons Color

01. Press  +  +  buttons for 2 seconds to access system menu.
02. Use  or  button to scroll to this  icon. Press **MODE** once.
03. Use  or  button to scroll and highlight the color choice.
04. Press the **MODE** button once to confirm.
05. Press **RESET/SNOOZE** to exit system menu.

Note: All icons will be changed to the new color, except the alert icons, low battery icon and the master mode.

Enabling alerts to unregistered CA-AX audio transmitter

CA-360Q will trigger an alert for all paired/registered accessories but you can enable the unit to trigger an alert for an un-paired CA-AX (audio/fire alarm) transmitter. To turn this function On/Off:

01. Press **🔊**+**2** buttons for 2 seconds or until the unit beeps.
The CA-AX icon will display on the unit!
02. Repeat setp 1 above to turn off.

Motion detection alerts On/Off

If you have a motion detector accessory (CA-MX) paired to the unit you need to enable this feature on the CA-360Q to alert you of any motion triggered by the CA-MX. To enable/disable motion detection:

01. Press **🔊**+ **MODE** buttons for 2 seconds or until the unit beeps.
The Motion detector icon will display on the unit!.
02. Repeat setp 1 above to diable.

Connect to an External Lamp (Model CA-LX)

SEREONIC Alert CA-360Q can control an external lamp via an optional external lamp module (Model CA-LX, purchased separately).

User can control the lamp **ON/OFF** using the **RESET** button on top of the unit. The operation of this lamp is synchronized with the flasher.

Note: The external lamp must be left in the **ON** position, and the lamp must be incandescent type using less than 100 watts.

Energy Saving Mode

Press the **Light Control** button (rear) for about 6 seconds. The display will be turned off and the unit will operate in battery mode. (with ac power attached). Press any button will cancel the mode.

All alerting functions are active during the energy saving mode.

RESET (Multi-Function Button):

The **RESET** button behavior under different conditions:

01. During alarm clock, press once will stop alarm sounds and starts a 5-minute snooze or press for 2 seconds will stop further snoozes.
02. In normal operations, press once will turn the flasher On / Off.
03. In battery mode, press once will turn display on for 3 seconds.
04. In menu setting, press once will exit the menu.
05. During alert alarms, press once will stop it, and reset all receivers.
06. Accessory low battery icon and warning message: press once will clear the message for 12 hours, and if press for more than 6 seconds, the CA-360Q will temporarily ignore the condition until the next accessory check-in signal is received.

Special Warning Message from CA-AX

Since the CA-AX (audio sensor) is primarily associate with detecting emergency sounds (example: fire alarms), it is important that the CA-360Q keeps constant monitoring with the registered CA-AX.

When the predetermined period has lapsed without receiving a signal from the CA-AX, a low-battery icon with the AX number will appear, and a warning message will be displayed. The message can only be cleared by the Reset button and will re-appear in 12-hours if the alerting status has not been cleared.

Special Note when CA-360Q running as a Remote Receiver:

When CA-360Q operates as a remote receiver, it can **ONLY** pair to a CA-360Q master unit and cannot pair any accessories to itself.

While the CA-360Q is in remote receiver mode, some critical system settings will be passed down from the master unit and will not be available to change. For normal operations, the user must perform a system reset to convert the CA-360Q back to a master mode.

Adding Extra Wireless Sensor Accessories to the system:

You can add additional accessories and the quantity of accessories as listed in the table below by following the “**Pairing Sensor Accessories to the system:**” instruction on page 11.

Wireless Accessory	Max Number Allowed
CA-AX (Fire Alarm)	10
CA-BX (Baby Monitor)	3
CA-CX (Cell Phone sensor)	1
CA-DB or CA-DX or CA-DXH (doorbell or knocker)	4 Any combination
CA-MX (Motion Sensor)	3
CA-NOAA (Weather alert)	1
CA-PX (Deaf/blind receiver)	10
CA-RX (Remote receiver)	10
CA-SOS (SOS transmitter)	4

To view registered accessories

Press the **MODE** button once will display all the accessories learned (registered) with the CA360Q for about 5 seconds.

Clear All Paired Accessories

Press the **MODE** button once will display all the accessories learned (registered) with the CA360Q for about 5 seconds.

Option 1: (will not reset alarm time)

01. Press **SOS/PAIR** button for 6 seconds to enter the LEARN mode. The display will show all the accessories registered.
02. Press the **SOS/PAIR** button 16 times in quick successions to clear.
03. When successful, the display will show no accessories.
04. Press the **RESET** button to exit.

Option 2: (will reset alarm time to 12:00)

Perform a system reset function, see in the later section.

SYSTEM MENU

Press + + buttons for 2 seconds to access system menu.

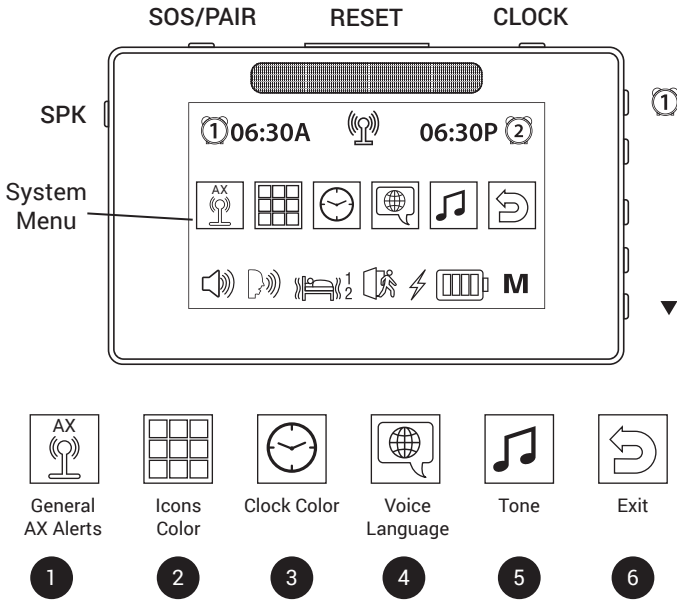

Note: Press RESET at any time will exit the menu

1. General CA-AX Alerts Enable / Disable

- Press or button to scroll and highlight this icon.
- Press the **MODE** button to enable / disable the function. An icon will show on the display when enabled.

When function is enabled, the unit will sound the alerts when **ANY** audio transmitter (CA-AX) that is in range and has been activated.

NOTE: The periodic check-in and low battery signals from these non-registered CA-AX units will not be acknowledged by the CA-360Q, so no warning messages will be generated.

2. Icons Color

- Use ▼ or ▲ button to scroll to this  icon. Press **MODE** once.
- Use ▼ or ▲ button to scroll and highlight the desired color.
- Press the **MODE** button to confirm. The display will return to the menu.

NOTE: All icons will be changed to the new color, except the alert icons, low battery icon and the master mode.

3. Clock Color

- Use ▼ or ▲ button to scroll to this  icon. Press **MODE** once.
- Use ▼ or ▲ button to scroll and highlight the desired color.
- Press the **MODE** button to confirm. The display will return to the menu.

4. Voice Announce Language Select

- Use ▼ or ▲ button to scroll to this  icon. Press **MODE** once.
- Use ▼ or ▲ button to scroll and highlight the choice.
- Press the **MODE** button to confirm. The display will return to the menu.

5. Alert Tone Select

- Use ▼ or ▲ button to scroll to this  icon. Press **MODE** once.
- Use ▼ or ▲ button to scroll and highlight the tone. A short sample of the tone will be played.
- Press the **MODE** button to confirm. The display will return to the menu.

6. Exit Menu

- Use ▼ or ▲ button to scroll to this  icon. Press **MODE** once. Exits menu and returns to clock display.

System Reset

System Default on CA-360Q is Master Mode (**M**).

To change the system mode, it must go through a system reset. All CA-360Q settings and paired accessories will be cleared.

Press  + ▼ buttons for 2 seconds to initiate.

1. A two level confirmation is needed:
The 1st level screen checks if still want to proceed,
Use ▲ or ▼ buttons to highlight the choice, press **MODE** to select:

Note: Pressing **RESET** at this time can cancel operation.

2. A 2nd screen will appear, select the **MAIN** or **SUB** system mode.
Use ▲ or ▼ button to highlight, and press **MODE** to confirm.
Press **RESET** will select the default selection "**MAIN**". (Master)

2. System reset is complete. All previous accessories are cleared.

NOTE: As a confirmation, the main clock separator will be differed:
"MASTER" mode – square shaped "SUB" (remote) mode – triangle shaped.

Technical Specifications:

1. Technology	2.4 GHz Smart-Code
2. Phone Ringing Input	>40 Vrms, 20 to 65 Hz
3. Phone jack type	RJ-11C
4. Bed-shaker output jack	9VDC, 150mA
5. External Lamp Control output jack	9VDC, 150mA
6. Display size	5 inches diagonal
7. Back-up batteries	4 x AA NiMH (~1200mAh)
8. AC Adapter output	9VDC, 2000mA
9. Operating temperature	10 to 40 C
10. Storage temperature	-10 to 50 C
11. Dimensions	168 x 105 x 60 mm
12. Weight	377g (with batteries)

Accessories for the Sereonic Alert

Model	Description
CA-AX	Wireless audio alarm sound monitor
CA-BX	Wireless baby-crying sound monitor
CA-CX	Wireless cellphone ringer/flasher
CA-DB	Wireless doorbell unit
CA-DX	Wireless door knocking sensor
CA-DXH	CA-DX with plastic door hanger
CA-LX	External Lamp control module
CA-MX	Wireless motion sensor to detect motion
CA-NOAA	Wireless NOAA (weather alert) radio output monitor
CA-PX	Wireless personal pager/receiver unit
CA-RX	Wireless remote receiver unit
CA-SOS	Wireless personal button for paging help
BS-100	Bed shaker
CA-BP	A pack of four (4) AA size NiMH rechargeable batteries

FAQ:

1. Must I install batteries in CA-360Q?

Ans: Batteries are for power outage back-up. The unit works with AC adapter and batteries are optional. It is strongly recommended that you install batteries.

2. What type of batteries does it need?

Ans: Please install rechargeable NiMH batteries only. Use of regular or non-rechargeable batteries will cause battery leakage, damage unit and void the product warranty.

3. What is the battery back-up time on CA-360Q?

Ans: About 7 days (normal operation, infrequent alerts)

4. Is it alright to place CA-360Q Master unit on a metal surface?

Ans: No! Only place it on a non-metallic surface. A metal surface attenuates wireless signal transmission and reduces its operating range.

5. Is the wireless doorbell water-resistant?

Ans: Yes, it is water resistant because it is protected with a rubber gasket. However, do not submerge in water.

6. How long does the doorbell battery last?

Ans: About 8 to 16 months (depends on how often you used it). Replace battery when its transmit indicator becomes dim or if its operation becomes less consistent.

7. How many doorbell units can my CA-360Q system support?

Ans: It can support a total of 4 units in any combination of doorbell (Model CA-DB), and door knock sensor (Model CA-DX).

8. How about other accessories?

Ans: Refer to the table in the "Adding Wireless Sensors". The system can support up to 10 Remote-Receivers (CA-RX), 10 Personal pagers (CA-PX), 10 audio sensors (CA-AX), 4 SOS pendants (CA-SOS), 3 Baby-Sound sensors (CA-BX), 1 Cell-phone sensor (CA-CX), and 1 NOAA sensor (CA-NOAA)

9. I just bought an extra doorbell for my CA-360Q system, but it did not work. What do I need to do?

Ans: All new accessory devices must be learned or registered by a CA-360Q master-unit before they can be worked or recognized.

10. I bought four CA-360Q systems for my home. Can I combine them into a single system?

Ans: Yes, you can. You need to convert three of the CA-360Q units from "Master" Unit into a "Remote-Receiver" so they can be learned (or registered) into the "Master" Unit.

11. How do I reset accessory's low battery icon on CA-360Q?

Ans: Press the RESET button for 6 seconds. This is only temporary. The low battery icon will appear again when the next accessory low battery signal is received.

12. What caused this accessory's low battery icon to show?

Ans: This message is associated with registered sensor's battery is either low, or not being turned on, or it may be placed too far from CA-360Q. Turn on its power or move the sensor closer to CA-360Q usually solve the issue.

13. I have difficulty in registering an accessory to my CA-360Q system. What should I do?

Ans: Make sure the CA-360Q is in pairing mode first, and you press the test button on the accessory for at least 6 seconds when registering, until you hear CA-360Q sounds and display the confirmation.

14. I have a large home, can I use two or more CA-360Q to increase coverage area?

Ans: Yes, CA-360Q and remote receivers has built-in repeater functions. Each unit can relay the signal it received to the next unit. This greatly increases effective coverage area.

15. Why is my CA-360Q displays "AX-0" ?

Ans: Your CA-360Q has enabled the "General CA-AX alerts" function. It has detected a nearby CA-AX sensor signal not part of its own. Refer to earlier section on general CA-AX alerts.

Warranty Service Information:

Your **Sereonic Alert** CA-360Q comes with (1) one-year limited warranty. We warrant during this warranty period – from the date of purchase to the original consumer – that the product is free from defects in materials and workmanship under intended home use. In the event that the product fails to function properly within one year of the original purchase due to defects in materials or workmanship, return the unit (freight prepaid) with proof of purchase (sales receipt or packing slip, no exceptions) to Serene Innovations. Serene Innovations will either repair or replace the unit (with a refurbished unit or a unit of equal condition) and return it to you (using UPS/USPS ground shipping) at no cost to you (there will be a nominal additional shipping charge if it is shipped to outside the 48 Continental U.S. States).

This warranty does not apply to any product that has been accidentally damaged due to: abused, misused or negligence, used on electrical frequency or voltage other than marked on product and/or described in this manual. Defects or errors caused by unauthorized alterations, repairs, and/or tampering are also not covered by this warranty.

Incidental or Consequential Damages:

Neither Serene Innovations, nor the retailer dealer, or selling distributor has any responsibility for any incidental or consequential damages, including, without limitation, commercial loss of profit, or for any incidental expense, loss of time, or inconvenience. Some states do not allow exclusion or limitation of incidental or consequential damage, so the above limitation or exclusion may not apply to you.

This Warranty gives you specific legal rights, and you may also have other legal rights that vary from state to state.

If a defect covered by this warranty should occur, promptly contact a Customer Care Representative by phone, or log onto www.sereneinnovations.com to obtain a Return Merchandise Number (RMA) and shipping instructions before shipping the product to us. Any shipment without a RMA will not be accepted and will be returned to you at your expense. Any authorized returned product must be accompanied by a proof of purchase and a brief explanation of the return problem.

For out-of-warranty repair and service, please contact our Customer Care Department for instructions.

FCC Part 68 Information and Rules

This equipment complies with Part 68 of the FCC rules and the requirements adopted by the ACTA. On the back of this equipment is a label that contains, among other information, a product identifier in the format US:AAAEQ##TXXXX. If requested, this number must be provided to the telephone company.

The REN is used to determine the quantity of devices which may be connected to the telephone line. Excessive REN's on the telephone line may result in the devices not ringing in response to an incoming call.

In most, but not all areas, the sum of the REN's should not exceed five (5.0). To be certain of the number of devices that may be connected to the line, as determined by the total REN's contact the local telephone company to determine the maximum REN for the calling area.

This equipment cannot be used on the telephone company-provided coin service. Connection to Party Line Service is subject to State Tariffs.

If this equipment causes harm to the telephone network, the telephone company will notify you in advance that temporary discontinuance of service may be required. If advance notice isn't practical, the telephone company will notify the customer as soon as possible. Also, you will be advised of your right to file a complaint with the FCC if you believe it is necessary.

The telephone company may make changes in its facilities, equipment, operations or procedures that could affect the operation of the equipment. If this happens, the telephone company will provide advance notice in order for you to make the necessary modifications to maintain uninterrupted service.

If trouble is experienced with this equipment, please contact:
Company Name: Serene Group, Inc.
Address: 14731 Carmenita Road, Norwalk, CA. 90650 USA
Tel: 562-407-5400
Fax: 562-483-2087

If the trouble is causing harm to the telephone network, the telephone company may request you to remove the equipment from the network until the problem is resolved.

This equipment uses the following USOC jacks: RJ11C.

It is recommended that the customer install an AC surge arrester in the AC outlet to which this device is connected. This is to avoid damaging the equipment caused by local lightning strike and other electrical surges.

If your home has specially wired alarm equipment connected to the telephone line, ensure the installation of this equipment does not disable your alarm equipment. If you have questions about what will disable alarm equipment, consult your telephone company or a qualified installer.

In the event this equipment should fail to operate properly, discontinue the unit from the telephone line. Try using another FCC approved telephone in the same telephone jack. If the trouble persists, call the telephone company repair service bureau.

If the trouble persists and appears to be with this unit, disconnect the unit from the telephone line and discontinue use of the unit until it is repaired. For repair or warranty information, please contact Serene Innovations at 562-407-5400. Please note that the telephone company may ask that you disconnect this equipment from the telephone network until the problem has been corrected or until you're sure that the equipment is not malfunctioning.

There are no user serviceable parts in this equipment.

FCC Part 15 Information and Rules:

This device complies with Part 15 of the FCC rules. Operation is subject to the following two conditions: (1) this device may not cause harmful interference, and (2) this device must accept any interference received, including interference that may cause undesired operation. This equipment has been tested and found to comply with the limits of a Class B digital device, pursuant to Part 15 of FCC rules. These limits are designed to provide reasonable protection against harmful interference in residential installation.

This equipment generates, uses, and can radiate radio frequency energy and, if not installed and used in accordance with the instructions, may cause harmful interference to radio communications. However, there is no guarantee that interference will not occur in a particular installation. If this equipment does cause harmful interference to radio or television reception, which can be determined by turning the equipment off and on, the user is encouraged to try correct the interference by one or more of the following measures:

1. Reorient the receiving antenna.
2. Increase the separation between the equipment and receiver.
3. Connect the equipment into an outlet on a circuit different from that to which the receiver is connected.
4. Consult the dealer or an experienced radio/TV technician for help.

Changes or modification not expressly approved by the party responsible for compliance could void your authority to operate the equipment.

Industry Canada Information and Rules

Notice: The Industry Canada label identifies certified equipment.

This certification means that the equipment meets telecommunications network protective, operational, and safety requirements as prescribed in the appropriate Terminal Equipment Technical Requirements document(s). The Department does not guarantee the equipment will operate to the user's satisfaction.

Before installing this equipment, users should ensure that it is permissible to be connected to the facilities of the local telecommunications company. This equipment must also be installed using an acceptable method of connection. The customer should be aware that compliance with the above condition may not prevent degradation of service in some situations.

Repairs to certified equipment should be coordinated by a representative designated by the supplier. Any repairs or alterations made by the user to this equipment, or equipment malfunctions, may give the telecommunication company cause to request that the user disconnect the equipment. Users should ensure, for their own protection, that the electrical ground connections of the power utility, telephone lines, and internal metallic water pipe system, if present, are connected together. This precaution may be particularly important in rural areas.

IC Compliance Statement

This product meets the applicable Innovation, Science and Economic Development Canada technical specifications.

Operation is authorized under the following two conditions:

- (1) This device may not cause interference.
- (2) This device must accept any interference, including interference that may cause undesired operation of the device.

This product meets CS-03

Caution: Users should not attempt to make such connections themselves, but should contact the appropriate electric inspections authority, or electrician, as appropriate. The REN for this device is stated on the IC regulatory label located on the back of the product.

Notice: The Ringer Equivalence Number (REN) indicates the maximum number of devices allowed to be connected to a telephone interface. The termination on an interface may consist of any combination of devices, subject only to the equivalent that the sum of the RENs of all the devices does not exceed five.

This Class B digital device complies with Canadian ICES-003, RSS-210